



## The Surveillance Cockpit for Total Control of the WJ-HD300 Series

Panasonic proudly introduces System Controller WV-CU650, the total system controller solution for our WJ-HD300 Series of Digital Disk Recorders. The Jog Dial and Shuttle Ring, positioned in the center of the unit, give you quicker, smoother, total control of every search operation and system setting. Plus, it also gives you one-touch access to Record, Replay, and Search functions. The detached joystick allows you to pan, tilt and zoom, seamlessly following the subject you are viewing. Use the larger numeric keypad for direct access to the camera of your choice when using cascade-linked WJ-HD300 Series recorders.

The WV-CU650 simplifies operation so that the operator can be focused on the surveillance task. The detached joystick can be used with either the right or left hand. Stick height can be adjusted to fit comfortably in the operator's hand. Soft padding minimizes fatigue during prolonged use. Buttons are laid out to facilitate touch recognition. User level management, user assignable buttons, set-up data transmission and other features make this controller outstandingly easy to manage. The WV-CU650 — It's so compact and easy to use. Think of it as the cockpit that maximizes the surveillance effectiveness of all your WJ-HD300 Series recorders.

### KEY FEATURES

---

- Controller for WJ-HD300 Series Digital Disk Recorders and other PS-Data devices
- Controller for Matrix System150

### Integrated System Control

---

#### Camera Control

- Detached joystick controls Pan/Tilt and Zoom, allowing seamless tracking.
- Larger numeric keypad provides direct access to cameras.

#### Recorder Control

- Jog Dial and Shuttle Ring for smoother control of WJ-HD300 Series recorders
- Dedicated Record, Play, and Search buttons

#### Switcher Control

- Image switching and sequencing buttons

### Easy to Operate While Focused on Surveillance

---

#### Universal Design for Right or Left Hand Use

- Detached joystick pad
- Layout with Jog Dial and Shuttle Ring in center

#### More Comfortable Extended Surveillance

- Soft padding on joystick
- Joystick adjustable for larger or smaller hands
- Low center of gravity design and adjustable angle minimize strain

#### Instinctive Operation

- Cockpit style button layout

### System Management Capability

---

- User level management for registered users
- User assignable buttons: four in main unit plus three in palm rest
- Setup data can be transferred via RS485

## SYSTEM EXAMPLE

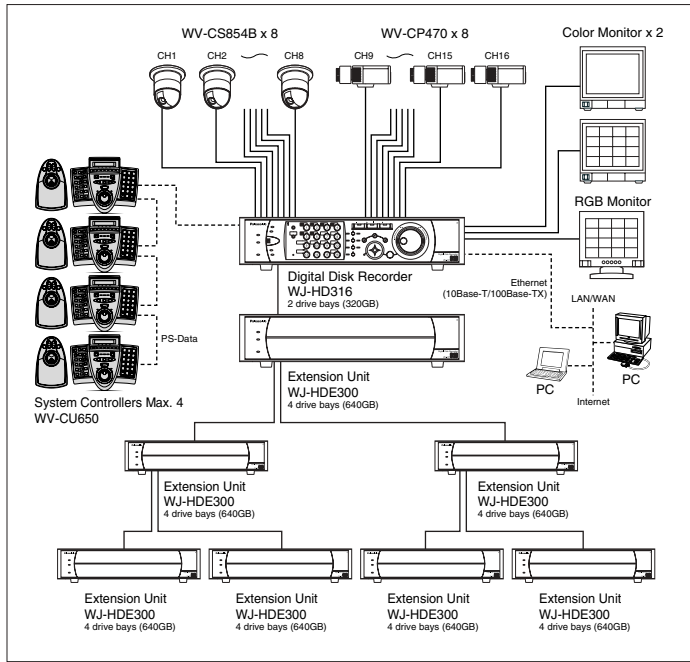

## APPEARANCE

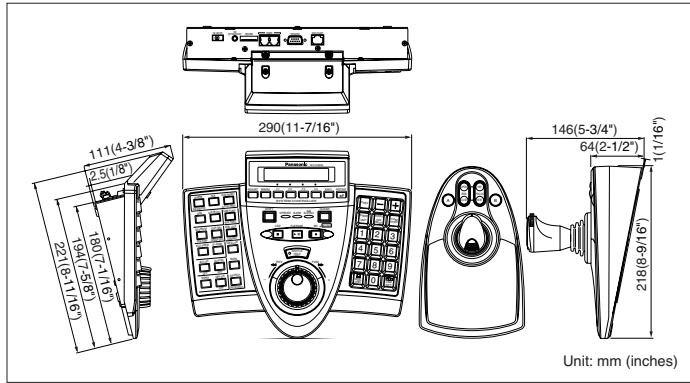

## SPECIFICATIONS

<b>Power Source</b>	9 V DC, 300 mA (using the supplied AC adapter)
<b>Power Source (Supplied AC Adapter)</b>	120 V AC, 60 Hz, 200 mA
<b>Data Output/Input Port</b>	6-conductor modular jack (RS-485, Full duplex) x2
<b>Serial Port</b>	9-pin D-sub connector
<b>Controller Number</b>	1 to 8 (rotary switch)
<b>Ambient Operating Temperature</b>	-10 °C to +50 °C (14 °F to 122 °F)
<b>Unit Number Selection</b>	1 to 99
<b>Monitor Number Selection</b>	1 to 99
<b>Camera Number Selection</b>	1 to 256
<b>Dimensions (W x H x D)</b>	290 x 146 x 221 mm (11-7/16" x 5-3/4" x 8-11/16")
<b>Weight (without the AC adapter)</b>	1.3 kg (2.86 lbs.)

## OPTIONAL COMPONENTS & ACCESSORIES

<p>Digital Disk Recorders <b>WJ-HD316</b> (16ch) <b>WJ-HD309</b> (9ch)</p> <p><b>PS•Data</b></p>	<p><b>MATRIX SYSTEM 150</b></p>	<p>Weather Proof &amp; Vandal Resistant Color Dome Camera <b>WV-CW864A</b></p>	<p>Super Dynamic II Color Dome Camera <b>WV-CS854B</b></p>	<p>Weather Proof Super Dynamic II Color Camera <b>WV-CW374</b></p>	<p>Vandal Proof Super Dynamic II Color Cameras <b>WV-CW474A Series</b></p>	<p>Color Monitors <b>WV-CM2080</b> 51cm (20") <b>WV-CM1780</b> 41cm (16") <b>WV-CM1480</b> 36cm (14") <b>WV-CM1420</b> 34cm (13") <b>WV-CM1020</b> 22cm (9")</p> <p><b>PS•Data</b></p>
--	---------------------------------	--	--	--	--	--

**Important** – Safety Precaution: carefully read the operating instructions and installation manual before using this product.

• Weights and dimensions are approximate. • Specifications are subject to change without notice. • These products may be subject to export control regulations.

# Panasonic

**Panasonic Digital Communications & Security Company**  
Unit of Matsushita Electric Corporation of America

**Security Systems Group**  
<http://www.panasonic.com/cctv>

**Executive Office** : Three Panasonic Way 2H-2, Secaucus, New Jersey 07094  
**Zone Office**

**Eastern** : Three Panasonic Way, Secaucus, New Jersey 07094 (201) 348-7303

**Central** : 1707 N.Randal Road, Elgin, IL 60123 (847) 468-5205

**Western** : 6550 Katella Ave., Cypress, CA 90630 (714) 373-7840

## MAJOR OPERATING CONTROLS

The diagram shows the control panel with numbered callouts 1 through 57. Below the diagram is a legend:

① Operation Indicator	⑱ Mark Button	㉔ LCD
② Alarm Indicator	⑲ Auxiliary 2 ON/OFF Button	㉕ Adjustment Button
③ Alarm Suspend Indicator	⑳ Auxiliary 1 ON/OFF Button	㉖ Menu Button
④ Shift Button	㉑ Search/Time and Date Search Button	㉗ Function Buttons
⑤ Clear Button	㉒ Defroster Button	㉘ Exit Button
⑥ Alarm Reset/Alarm All Reset Button	㉓ Wiper Button	㉙ Enter Button
⑦ Alarm Acknowledge Button	㉔ Stop Button	㉚ Joystick Connector
⑧ Alarm/Alarm Suspend Button	㉕ Play/Pause Button	㉛ Serial Port
⑨ Camera Function/ System Function Button	㉖ Recording Button	㉜ Data Ports
⑩ Alarm Recall Button	㉗ Shuttle Ring (Outside)/JogDial (Inside)	㉝ Mode Selection Switches
⑪ On-Screen Display Button	㉘ Shuttle Hold Button	㉞ Controller Number Switch
⑫ Monitor Lock/Logout Button	㉙ Preview Button	㉟ DC 9V Input Jack
⑬ Tour Sequence/ Group Sequence Button	㉚ - Button	㊱ + Button
⑭ Sequence Pause/ Sequence Stop Button	㉛ Recorder/Unit Selection Button	㊲ Recorder/Unit Selection Button
⑮ Go To Last Button	㉜ Preset/Program Preset Button	㊳ Preset/Program Preset Button
⑯ Electronic Zoom Button	㉝ Camera Position Button	㊴ Camera Position Button
⑰ Multiscreen Selection Button	㉞ Numeric Buttons	㊵ Numeric Buttons
	㉟ Monitor/Escape Button	㊶ Monitor/Escape Button
	㊱ Camera/Set Button	㊷ Camera/Set Button

DISTRIBUTED BY:

**PANASONIC CANADA INC.**

5770 Ambler Drive, Mississauga, Ontario, L4W 2T3 Canada (905) 624-5010

**PANASONIC SALES COMPANY**

**DIVISION OF MATSUSHITA ELECTRIC OF PUERTO RICO, INC.**

San Gabriel Industrial Park 65th Infantry Ave. KM. 9.5 Carolina, P.R. 00985 (809) 750-4300

Printed in Japan  
WW-JHC650T(2P-XXX)